



● M23 for power

Material and spec

Shell material	Zinc alloy with nickel plating
Contact material	Brass with gold plating
Insert material	PA66
Insulation resistance	>10 ¹³ mΩ
Termination	Crimp
Temperature range	-40°C ~ +125°C
Mating cycle	1000
Cable outer diameter range	I: 4-8mm (Special order) II: 8-13mm (Standard) III: 12-17mm (Special order)
IP rating	IP67
Coupling	Threaded coupling



Male contact cable connector

M23DJ_TK

Number of contact

- GY
- BK, OG
- BU, GN
- PL

- Cable outer diameter range
- I: 4-8mm (Special order) II: 8-13mm (Standard)
- III: 12-17mm (Special order)
- S: Shield
- U: Unshielded



Colour
Gray: GY (Standard)
Black: BK (Special order), Orange: OG (Special order)
Blue: BU (Special order), Green: GN (Special order)
Purple: PL (Special order)



Female contact cable connector

M23DK_TK_

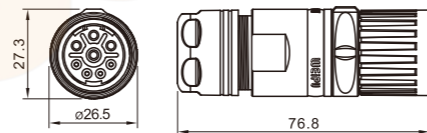

Male contact square flange receptacle

M23DJ_Z

Number of contact

- GY
- BK, OG
- BU, GN
- PL

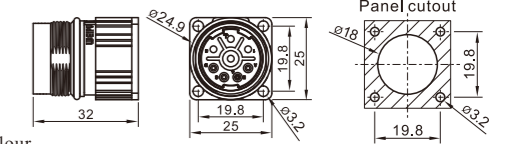

Colour
Gray: GY (Standard)
Black: BK (Special order), Orange: OG (Special order)
Blue: BU (Special order), Green: GN (Special order)
Purple: PL (Special order)



Female contact square flange receptacle

M23DK_Z_

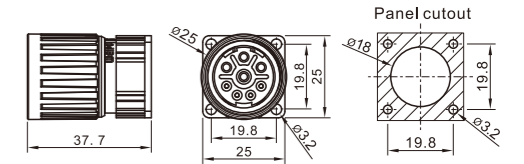

Male contact angled cable connector

M23DJ_TL_

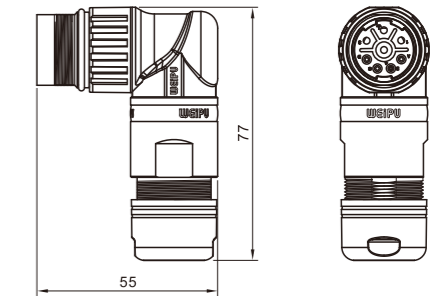

Female contact angled cable connector

M23DK_TL_

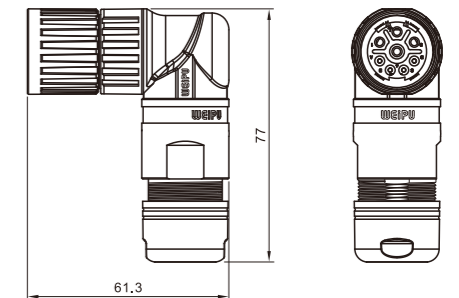

Male contact angled square flange receptacle

M23DJ_ZL_

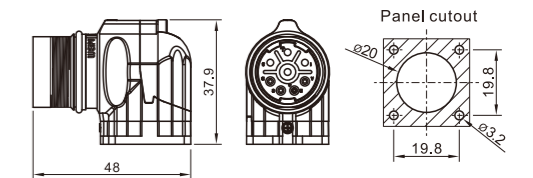

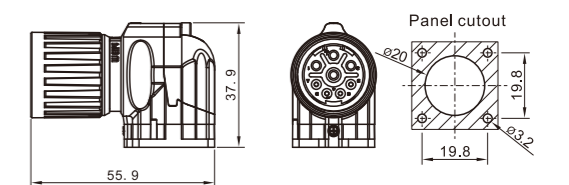

Female contact angled square flange receptacle

M23DK_ZL_



M23 for power contact arrangement and spec

01

Male contact face view	Number of contact	Contact diameter (mm)	Rated voltage (AC.V)	Rated current (A)	Test voltage (AC.V)1min
	6(5+PE)	∅2	600	28	4000
	8(3+4+PE)	∅1×4 ∅2×4	300 600	8 28	2500

M23 contact spec

01

8A Crimp contact

- ※ Contact diameter: ∅1
- ※ Material: Brass with gold plating

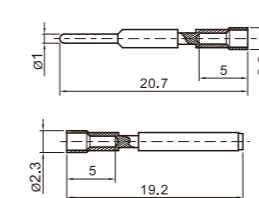

8A Male crimp contact

Wire size	Stripping length	Male crimp contact p/n	Crimping tool p/n
0.08-0.5mm ² AWG 28-20	4mm	YJ1-20.7-0.56AU	CTW-0.14/4
0.25-1.0mm ² AWG 23-17	4mm	YJ1-20.7-1.0AU	CTW-0.14/4

8A Female crimp contact

Wire size	Stripping length	Female crimp contact p/n	Crimping tool p/n
0.08-0.5mm ² AWG 28-10	4mm	YK1-19.2-0.56AU	CTW-0.14/4
0.25-1.0mm ² AWG 23-17	4mm	YK1-19.2-1.0AU	CTW-0.14/4

28A Crimp contact

- ※ Contact diameter: ∅2
- ※ Material: Brass with gold plating

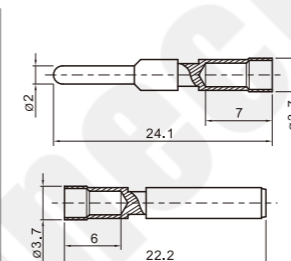

28A Male crimp contact

Wire size	Stripping length	Male crimp contact p/n	Crimping tool p/n
0.08-0.5mm ² AWG 28-20	7mm	YJ2-24.1-0.56AU	CTW-0.14/4
1-2.5mm ² AWG 18-13	7mm	YJ2-24.1-2.5AU	CTW-0.14/4
2.5-4mm ² AWG 13-12	7mm	YJ2-24.1-4.0AU	CTW-0.14/4

28A Female crimp contact

Wire size	Stripping length	Female crimp contact p/n	Crimping tool p/n
0.08-0.5mm ² AWG 28-20	6mm	YJ2-22.2-0.56AU	CTW-0.14/4
1-2.5mm ² AWG 18-13	6mm	YK2-22.2-2.5AU	CTW-0.14/4
2.5-4mm ² AWG 13-12	6mm	YK2-22.2-4.0AU	CTW-0.14/4

Crimp tool

For crimping the male / female contacts



Part number	Crimping wire range
CTW-0.14/4	0.08-4mm ² AWG 28-11



● M23 for signal

Material and spec

Shell material	Zinc alloy with nickel plating
Contact material	Brass with gold plating
Insert material	PA66
Insulation resistance	9, 12 pins: >10 ¹⁰ mΩ 17, 19 pins: >10 ⁸ mΩ
Termination	Crimp
Temperature range	-40°C ~ +125°C
Mating cycle	1000
Cable outer diameter range	I: 4-8mm (Special order) II: 8-13mm (Standard) III: 12-17mm (Special order)
IP rating	IP67
Coupling	Threaded coupling



Male contact cable connector

M23SJ TK

Number of contact

- (P01-07)
- N, S
- H, X
- Y, Z
- Cable outer diameter range
- I: 4-8mm (Special order) II: 8-13mm (Standard)
- III: 12-17mm (Special order)
- S: Shield
- U: Unshielded

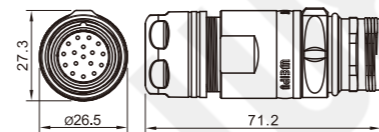

Coded chuck (See P01-07)
N: Gray (Standard), S: Black (Special order)
H: Orange (Special order), X: Blue (Special order)
Y: Green (Special order), Z: Purple (Special order)



Female contact cable connector

M23SK TK

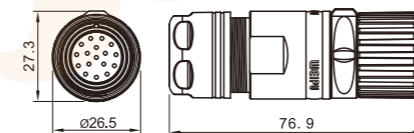

Male contact square flange receptacle

M23SJ_Z

Number of contact

- (P01-07页)
- N, S
- H, X
- Y, Z

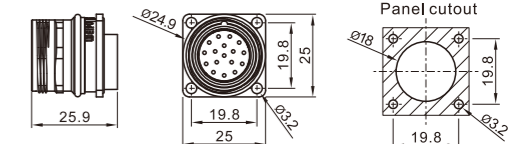

Coded chuck (See P01-07)
N: Gray (Standard), S: Black (Special order)
H: Orange (Special order), X: Blue (Special order)
Y: Green (Special order), Z: Purple (Special order)



Female contact square flange receptacle

M23SK_Z

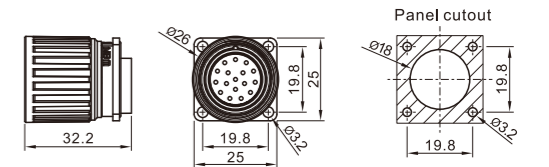

Male contact angled cable connector

M23SJ_TL

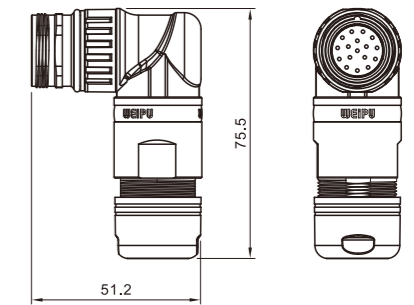

Female contact angled cable connector

M23SK_TL

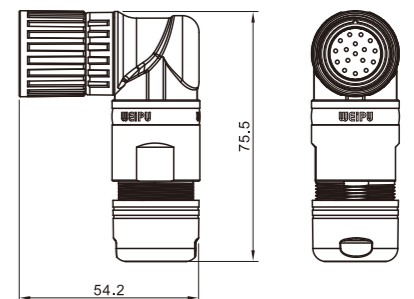

Male contact angled square flange receptacle

M23SJ_ZL

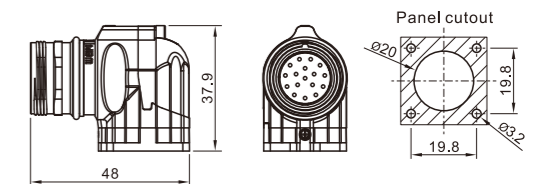

Female contact angled square flange receptacle

M23SK_ZL

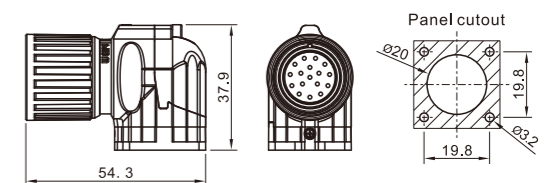

Male contact face view	Number of contact	Contact diameter (mm)	Rated voltage (AC.V)	Rated current (A)	Test voltage (AC.V)1min
	9(8+1)	∅1×8 ∅2×1	300	8 20	2500
	12	∅1×12	300	8	2500
	17	∅1×17	150	8	1500
	19(16+3)	∅1×16 ∅1.5×3	150	8 10	1500

Number of Contact	Optional Angle	Coded Chuck
9	N, S, H, X, Y	 Male contact face view Female contact face view
12	N, S, H, X, Y, Z	
17	N, S, H, X, Y, Z	
19	N, S, H, X, Y	

Code N is open in original state, if you need to use another, please open the coded chuck head.

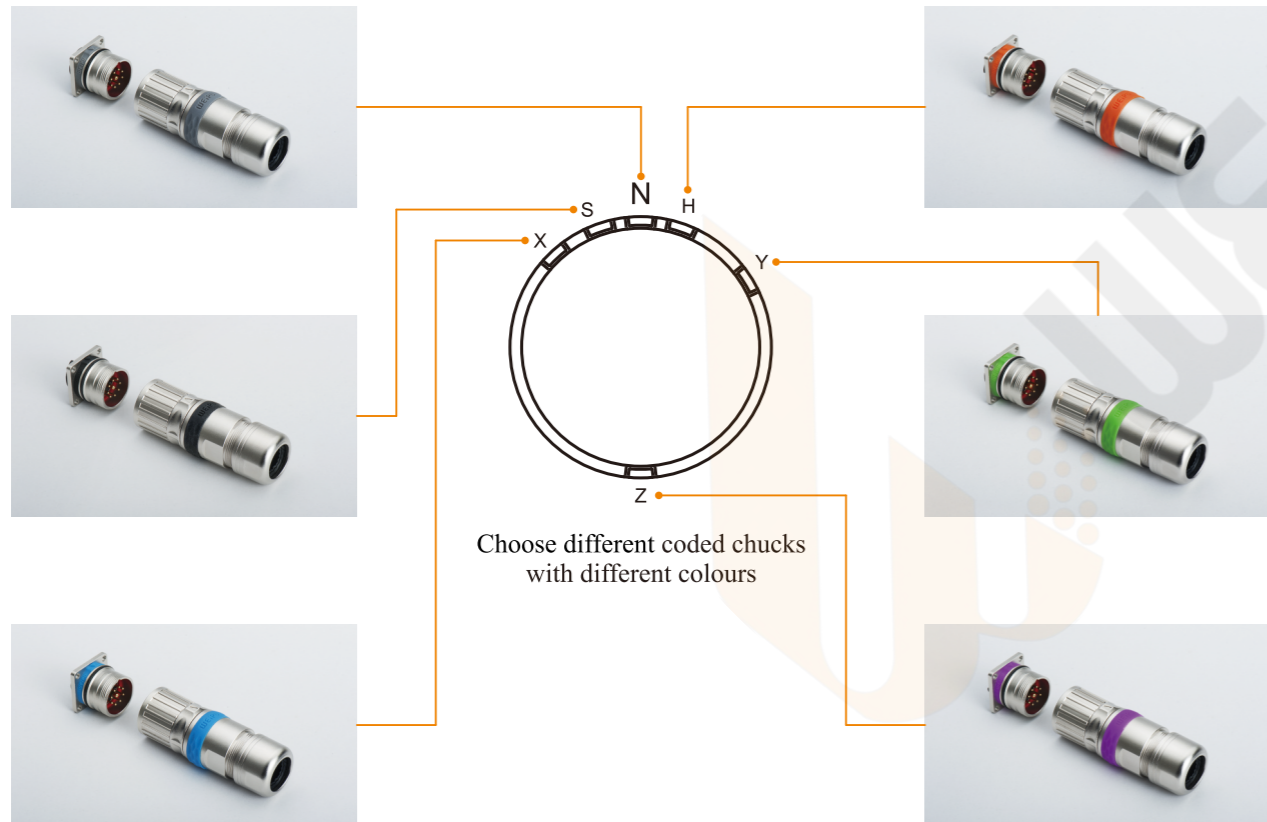

8A Crimp contact

※ Contact diameter: ∅1
 ※ Material: Brass with gold plating

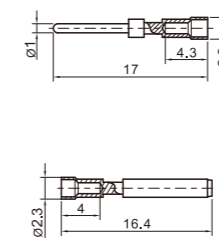
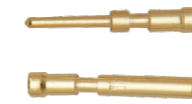

Wire size	Stripping length	Male crimp contact p/n	Crimping tool p/n
0.08-0.5mm ² AWG 28-20	4mm	YJ1-17-0.56AU	CTW-0.14/4
0.56-1mm ² AWG 20-17	4mm	YJ1-17-1.0AU	CTW-0.14/4
1-1.5mm ² AWG 17-16	4mm	YJ1-17-1.5AU	CTW-0.14/4

Wire size	Stripping length	Female crimp contact p/n	Crimping tool p/n
0.08-0.5mm ² AWG 28-20	4mm	YK1-16.4-0.56AU	CTW-0.14/4
0.56-1mm ² AWG 20-17	4mm	YK1-16.4-1.0AU	CTW-0.14/4
1-1.5mm ² AWG 17-16	4mm	YK1-16.4-1.5AU	CTW-0.14/4

10A Crimp contact

※ Contact diameter: ∅1.5
 ※ Material: Brass with gold plating

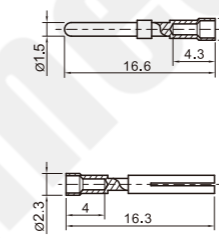
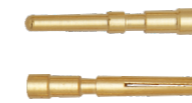

Wire size	Stripping length	Male crimp contact p/n	Crimping tool p/n
0.14-0.5mm ² AWG 26-20	4mm	YJ1.5-16.6-0.56AU	CTW-0.14/4
0.5-1mm ² AWG 20-17	4mm	YJ1.5-16.6-1.0AU	CTW-0.14/4
1-1.5mm ² AWG 17-16	4mm	YJ1.5-16.6-1.5AU	CTW-0.14/4

Wire size	Stripping length	Female crimp contact p/n	Crimping tool p/n
0.14-0.5mm ² AWG 26-20	4mm	YK1.5-16.3-0.56AU	CTW-0.14/4
0.56-1mm ² AWG 20-17	4mm	YK1.5-16.3-1.0AU	CTW-0.14/4
1-1.5mm ² AWG 17-16	4mm	YK1.5-16.3-1.5AU	CTW-0.14/4

20A Crimp contact

※ Contact diameter: ∅2
 ※ Material: Brass with gold plating

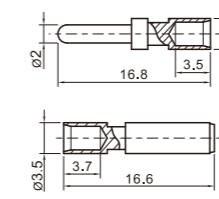

Wire size	Stripping length	Male crimp contact p/n	Crimping tool p/n
0.75-2.5mm ² AWG 18-13	3.5mm	YJ2-16.8-2.5AU	CTW-0.14/4

Wire size	Stripping length	Female crimp contact p/n	Crimping tool p/n
0.75-2.5mm ² AWG 18-13	3.5mm	YK2-16.6-2.5AU	CTW-0.14/4

Crimping tool

For crimping the male / female contacts



Part number	Crimping wire range
CTW-0.14/4	0.08-4mm ² AWG 28-11